



## AdaptaBeacon® Light Duty Strobe with Horn

**85 dB Audible/Visual Signal**

### 95 Series

#### FEATURES

- > Weatherproof
- > Optically designed fresnel lens
- > Internal, base mounted horn - rated at 85 dB at 10 feet (3.05 m)
- > Immune to shock and vibration
- > Cast base may be used as a junction box

#### AGENCY APPROVALS

- > UL 1638 Listed
- > cUL Listed

The Edwards 95 Series AdaptaBeacon Light Duty strobe lights with internal horn are designed for light duty applications in industrial, commercial, and institutional applications where short term intermittent visual signaling is required. A series of complementing fresnels that cause the dome to "fill" with light each time the strobe flashes. This design feature increases the AdaptaBeacon "on-time", thus improving viewer perception. Beam distance is increased with external fresnel lenses. Trigger and timing circuits are included as integral parts of the power supply. Replacement costs are reduced as it is necessary to replace only the strobe tube.

Designed for indoor or outdoor installation. May be direct, 1/2" (13mm) conduit, or box mounted on a 4" (102mm) octagon box on any plane. However, vertical installation ensures maximum beam width projection. For weatherproof installations units must be mounted vertically with dome up. May be corner mounted using the Cat. No. CBR, corner mount bracket, or wall mounted using the Cat. No. WBR, wall mount bracket. Cat. No. 92-GRD lens guard is available for additional protection against lens breakage. See AdaptaBeacon Accessories, pg. 3-118.

They are ideally suited for installations where high ambient light levels make traditional rotating or flashing lights difficult to distinguish or where ambient noise levels make audible signals difficult to hear. Usually used for signaling equipment malfunctions, security intrusions, or pinpointing problem locations. The gasketed weatherproof design assures installation acceptability in most industrial and commercial locations.



## TECHNICAL INFORMATION

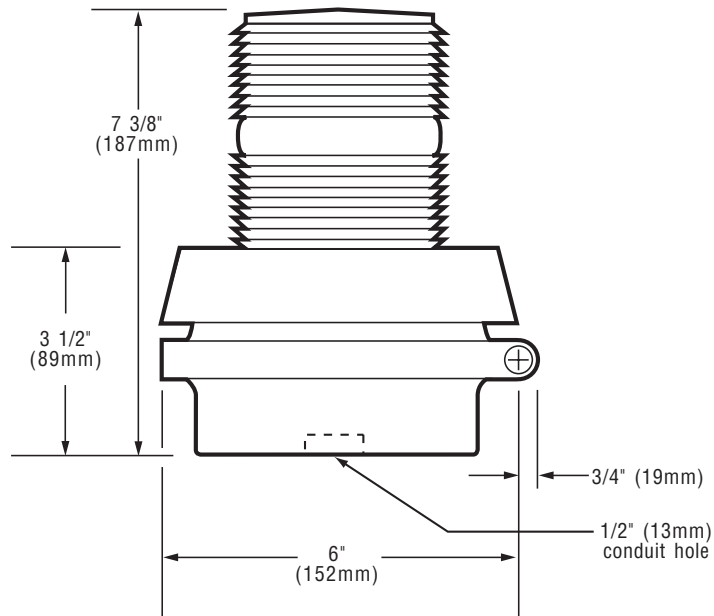

Cat. No.	Lens Color	Replacement Lens	Electrical Rating	Flash Rate	Replacement Strobe Tube	Peak Candlepower
95R-N5	Red	92-LR	120V 50/60 Hz	65 FPM	92-LST	1,400,000 cd
95A-N5	Amber	92-LA	0.1 Amps		5,000 hour*	
95B-N5	Blue	92-LB				
95G-N5	Green	92-LG				
95M-N5	Magenta	92-LM				
95C-N5	Clear	92-LC				

\*Calculated at operating power to 75% efficiency.